

PA DOT PennDOT 8" M Frame

0PA535500003

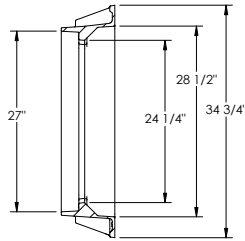

5356Z Frame

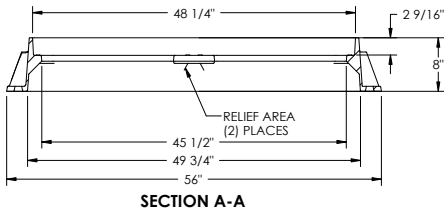
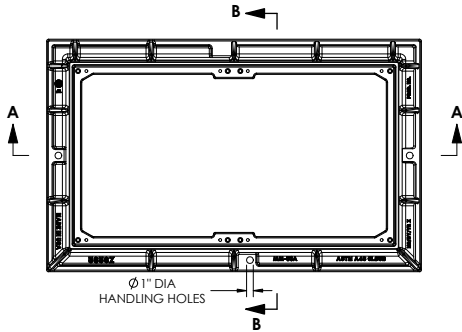

SECTION B-B



Product Number

00535613

Design Features

- Materials
- Gray Iron (CL35B)
- Design Load
- Heavy Duty
- Open Area
- rfla
- Coating
- Undipped
- √ Designates Machined Surface

Certification

- ASTM A48
-
- Country of Origin: USA

Drawing Revision

8/27/2012 Designer: DJH
01/17/2013 Revised By: DAE

Disclaimer

Weights (lbs/kg), dimensions (inches/mm) and drawings provided for your guidance. We reserve the right to modify specifications without prior notice.

CONFIDENTIAL: This drawing is the property of EJ Group, Inc. and embodies confidential information, registered marks, patents, trade secret information, and/or know how that is the property of EJ Group, Inc. Copyright © 2012 EJ Group, Inc. All rights reserved.

Contact

800 626 4653
ejco.com

00535613

Quantity: 1

Disclaimer

Weight (lbs./kg), dimensions (inches/mm) and drawings provided for your guidance. We reserve the right to modify specifications without prior notices

CONFIDENTIAL: This drawing is the property of EJ GROUP, Inc., and embodies confidential information, registered marks, patents, trade secret information, and/or know how that is the property of EJ GROUP, Inc. Copyright © 2017 EJ GROUP, Inc. All rights reserved

Contact

800 626 4653
ejco.com